



# AXIOM

Fixed gas detector

AXIOM series of gas detectors is explosion-proof and designed for continuous monitoring of hazardous concentrations of flammable, toxic gases, volatile organic compounds (VOC) and oxygen (O<sub>2</sub>) in the air of the working area.



## Features and benefits



- Applicable sensor types: PID, LEL, EC, MEMS and IR (hydrocarbons, CO<sub>2</sub>, freons);
- Simultaneous presence of output signals: 4-20 mA/HART, relay: “Threshold 1”, “Threshold 2”, “Threshold 3/ Alarm”, RS-485 Modbus RTU;
- Replacing the sensor without removing the power supply from the sensor (hot);
- Possibility of replacing the sensor with another type;
- Ambient temperature range from -60°C to +65°C;
- LED status indicator (operation, error, service);
- Availability of explosion-proof light and sound alarm MX-SLA\*;
- Bright OLED display for displaying readings and accessing menus;
- Access to settings and calibration: magnetic key, HART, HART connector\*, RS-485 (Modbus), Bluetooth\*;
- Four holes for two cable entries (4-20 and relay), HART, MX-SLA siren.

- 3 years warranty
- 20 years service life

\* Optional

## SMART-sensor

- Non-volatile memory of the SMART sensor for storing settings;
- The built-in temperature sensor provides adaptive heating of the SMART sensor.

Gases	Explosive gases, toxic gases, volatile organic compounds (VOC) , freons, oxygen
Temperature Range	-60°C to +65°C*
Ex marking	1 Ex d [ia Ga] IIC T6 Gb X
Ingress Protection	IP66/ IP67
Supply Voltage	24V (nominal) Range: 12-36V
Communication	OLED-display 4-20 mA HART RS-485 (Modbus) Bluetooth (for gas detector configuration)* 3 Relays "Threshold 1", "Threshold 2", "Threshold 3/Accident"
Permissible Humidity	< 98% (non-condensing)
Operating Pressure	80 - 120 kPa
Measurement Mode	< 2 W
Nominal Settling Time Of The Output Signal	10 sec IR 15 sec LEL, MEMS 30 sec EC
At The Level T0.9	30 sec PID
Gas Analyzer Warm-up Time Limit	10 min IR, PID 60 min LEL, EC 20 min MEMS
Mean time between failures	100000 h IR 35000 h LEL, EC, PID 70000 h MEMS
Customization	Magnetic key, Bluetooth*, HART, RS-485 (Modbus)
Material	Aluminum alloy, stainless steel 316L
Dimensions	150x110x235 mm
Weight	2,6 kg. (aluminum alloy), 4,5 kg. (stainless steel)

## Modifications

ATOM-MEMS with semiconductor sensor

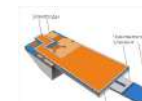

ATOM-IR with infrared sensor

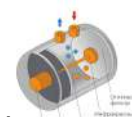

ATOM-LEL with thermocatalytic sensor

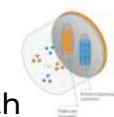

ATOM PID with photoionization sensor



ATOM-EC with electrochemical sensor

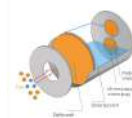

\*Optional

## Accessories



## Fast and convenient installation

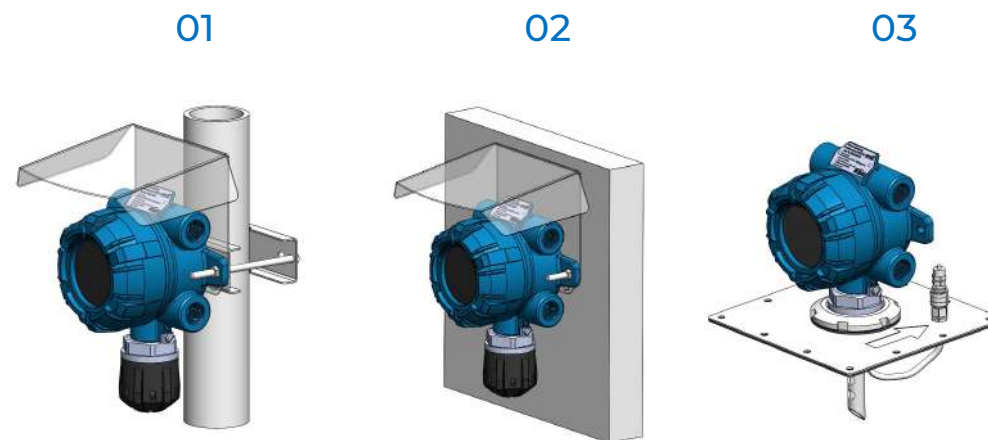

- 01. Light and sound siren MX-SLA
- 02. HART connector
- 03. Anti-vandal protection
- 04. Insect guard
- 05. Calibration nozzle
- 06. Protective visor from the sun and precipitation
- 07. Pipe mounting kit (pipe diameter 38-68 mm)
- 08. Duct mounting kit

- 01. Type of mounting for pipe mounting
- 02. Mounting type for wall mounting
- 03. Type of fastening for installation in an air duct



[www.mirax-safety.com](http://www.mirax-safety.com)