



# ATOM

Fixed gas detector

ATOM series of gas detectors is explosion-proof and designed for continuous monitoring of hazardous concentrations of flammable, toxic gases, volatile organic compounds (VOC) and oxygen (O<sub>2</sub>) in the air of the working area.





## Features and benefits

- Applied sensor types: PID, LEL, EC, MEMS and IR (hydrocarbons, CO2);
- Detection of the presence of output signals: 4-20 mA and HART;
- Ability to detect a sensor on another type;
- Temperature and ambient range from -60°C to +65°C;
- LED status indicator (work, error, service); Bright OLED display for display and menu access;
- Settings and parameters are available: magnetic key, HART, Bluetooth\*, UART (for service connection);
- Two holes for cable entry M20 / M25.

## SMART-sensor

- 3 years warranty
- 20 years service life

- Non-volatile memory of the SMART sensor for storing settings;
- The built-in temperature sensor provides adaptive heating of the SMART sensor.

*\* Optional*

Gases	Explosive gases, toxic gases, oxygen
Temperature Range	-60°C to +65°C
Ex marking	1 Ex d IIC T6 Gb X
Ingress Protection	IP66, IP68, IP69
Supply Voltage	24V (nominal) Range: 16-36V
Communication	OLED-display 4-20 mA HART Bluetooth*
Permissible Humidity	< 98% (non-condensing)
Operating Pressure	80 - 120 kPa
Measurement Mode	< 2 W
Nominal Settling Time Of The Output Signal At The Level T0.9	10 sec IR 15 sec LEL, MEMS 30 sec EC 30 sec PID
Gas Analyzer Warm-up Time Limit, no more	10 min IR, PID 60 min LEL, EC 20 min MEMS
Mean time between failures	100000 h IR 35000 h LEL, EC, PID 70000 h MEMS
Customization	Magnetic key Bluetooth* HART USB-UART adapter for PC
Material	Aluminum alloy, stainless steel 316L
Dimensions	156x120x105 mm
Weight	2 kg (aluminum alloy), 3,9 kg (stainless steel)

## Modifications

ATOM-MEMS with semiconductor sensor

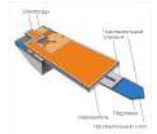

ATOM-IR with infrared sensor

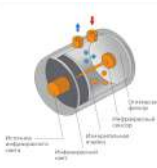

ATOM-LEL with thermocatalytic sensor

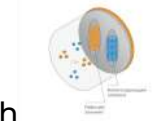

ATOM PID with photoionization sensor



ATOM-EC with electrochemical sensor

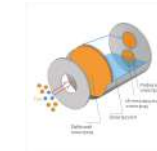

\*Optional

## Accessories

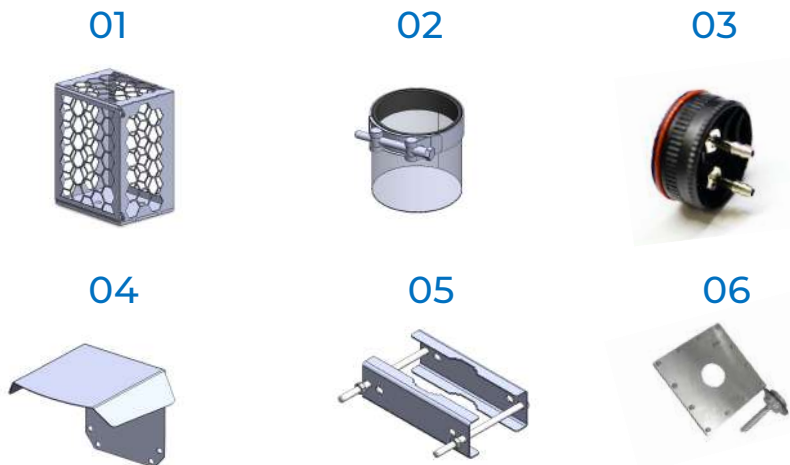

- 01. Anti-vandal protection
- 02. Insect guard
- 03. Calibration nozzle
- 04. Protective visor from the sun and precipitation
- 05. Pipe mounting kit (pipe diameter 38-68 mm)
- 06. Duct mounting kit

## Fast and convenient installation

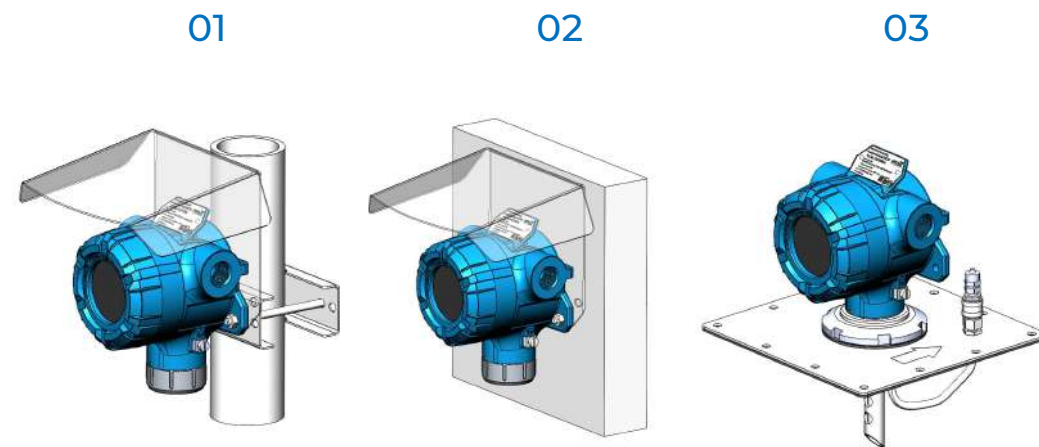

- 01. Type of mounting for pipe mounting
- 02. Mounting type for wall mounting
- 03. Type of fastening for installation in an air duct



[www.mirax-safety.com](http://www.mirax-safety.com)